



- Third Party Verified Category 6A Component Exceeds TIA and ISO Limits
- Exclusive 1-Punch Termination Reduces Termination Time by 75%
- Mating Cycles Exceed Industry Standard by 4 Times
- Bulk and Green Packaging Reduces Excess Waste on the Job

FEATURES

- 4.5db min NEXT margin over TIA 568-C.2 component at 500MHz
- 1.5 dB min NEXT margin over ISO component
- Supports permanent links: 2 - 295 meters
- Enhanced common mode design eliminates residual and reflected NEXT and ANEXT
- Designed and tested for 850mA of continuous current per conductor (1.7A per pair).
- Manufacturing: 100% factory tested

SPECIFICATIONS

- Nose contact material: beryllium copper with precious metal plating with nickel under-plating
- Contact performance confirmed over the full range of ISO/FCC compliant plug dimensions
- Packaging: carton 100% recycled material – bag 85% recycled material

STANDARDS

- TIA-568-C.2 Category 6A component
- ISO 11801/60603-7 Category 6A component
- Channel: Third-Party tested for TIA 568-C.2 Category 6A and ISO 11801 Class E_A
- Application: Third-Party qualified for 10 Gigabit Ethernet Transmission IEEE 802.3an
- Current Capacity: Exceeds current levels for PoE and PoE+ IEEE 802.3at
- Mechanical: Verified to TIA-568-C.2
- UL Listed 1863

HUBBELL NextSpeed Ascent Jacks Category 6A Jacks

Versatility
 NEXTSPEED® Ascent Jack fits in all Hubbell iSTATION, delivery and cross connect products.

Performance
 Patented zero-crosstalk contact structure provides the highest performance while maintaining true balance.

Capacity
 Small form factor allows up to 6 jacks in a single gang or 48 jacks in a 1-U panel without restriction or constraints.

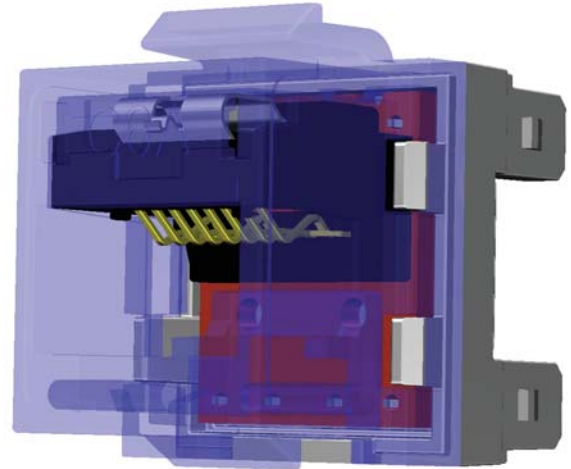

Superior Strain Relief
 Locking IDC stuffer cap ensures termination retention, securing wires during installation.

IDC Lacing
 IDC towers have an inner blade to assist in pair splitting without performance disruption.



NEXTSPEED® Ascent Category 6A solution is a tuned system of structured cabling components designed and balanced to work together to deliver bandwidth beyond 625MHz.

NEXTSPEED Ascent Category 6A jack is third party verified exceeding TIA and ISO performance component requirements. The well balanced design of the HJ6A allows all NEXTSPEED Ascent components to be utilized in links under 10 meters, providing a fully compliant system from 2 to 295 meters.

HJ6A Jack provides superior ANEXT, cutting edge enhanced common mode design and industry leading performance on RL, NEXT and all critical parameters. The HJ6A jack is the new product for a new digital world, produced and packaged in the most environmentally conscious “Green” manner in the USA.

APPLICATIONS

- 10GBASE-T (10-Gigabit Ethernet)
- Consolidation, Server Clustering & Scalability Virtualization
- Mass Data Storage, Storage Area Networks (SAN)
- Web enablement of applications (WEB 2.0)
- Voice Protocol – VoIP, SIP, SCCP, MGCP
- Video Protocol – IPTV, RTSP, RTP



ORDERING INFORMATION

Description	1 Jack per package	25 Jacks per package
NEXTSPEED® Ascent C6A Component Jack	HJ6AXX	HJ6AXX25

XX = Jack Color Options

AL=Almond	BK=Black	B=Blue	El=Electric Ivory	GL=Gold	GY=Gray	GN=Green	LA=Light Almond
OW=Office White	OR=Orange	P=Purple	R=Red	W=White	Y=Yellow		

ACCESSORIES

NEXTSPEED® Ascent Category 6A Patch Cords

Color	Catalog Number
Gray	PC6AGYXX

GY Standard Colors - B=Blue; BK=Black; GY=Gray; Y=Yellow.
 For other colors replace use one of the following: OR=Orange, R=Red, GN=Green, P=Purple, W=White
 XX Standard Lengths - 03=3'; 05=5'; 07=7'; 10=10'; 15=15'; 20=20'
 MTO Lengths - 30', 35', 40', 45', 50', 55', 60', 65', 75', and 100'



NEXTSPEED® Ascent Category 6A Patch Panel



Ports	Height	Rack Units	Black Catalog Number	Silver Catalog Number
24	1.75" (45)	1	HP6A24U	HP6A24US
48	3.50" (89)	2	HP6A48U	HP6A48US
96	7.00" (178)	4	HP6A96U	HP6A96US

NEXTSPEED® Ascent Category 6A Cable

Description	Plenum Spool	Riser Spool
Category 6A UTP Cable	C6ASPXX	C6ASRXX

XX = Cable Color Options

B=Blue	GY=Gray	W=White	Y=Yellow
--------	---------	---------	----------

XX = MTO Cable Color Options

G=Green	OR=Orange
---------	-----------



Assemblies

BIDnet™ pre-terminated Category 6A Copper Trunk Assemblies are the ideal solution for data centers, open office and other applications where accuracy, reliability and performance are the most important factors. BIDnet™ assemblies provide simplicity for permanent links between switches, servers and patch panels.



All BIDnet™ pre-terminated cable assemblies are made-to-order items. Please call our inside sales team for lead-time and availability.

DIMENSIONS

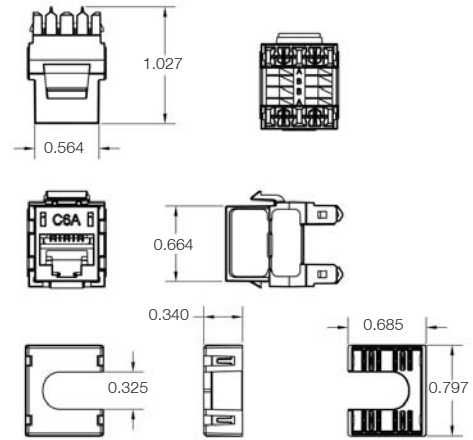

INTEGRATED SOLUTIONS



Work Station & Cross-Connect Solutions

- All Hubbell I-Station Products, Front-Loading, Rear-Loading, Frames, Bezels and Surface Mount Boxes
- All UDX Multimedia Panels



Delivery Systems Solutions

- SystemOne, Poke Throughs, Concrete & Raised Access Floor Boxes
- Multi-Connect Wall Boxes & Conference Table Boxes
- Raceway Metal & Non-Metallic

TYPICAL APPLICATION

Cat 6A - 10 Gigabit Ethernet has become the standard for connecting active gear in data centers.

BIDnet™ Cat 6A assemblies provide simplicity between switches, servers and patch panels

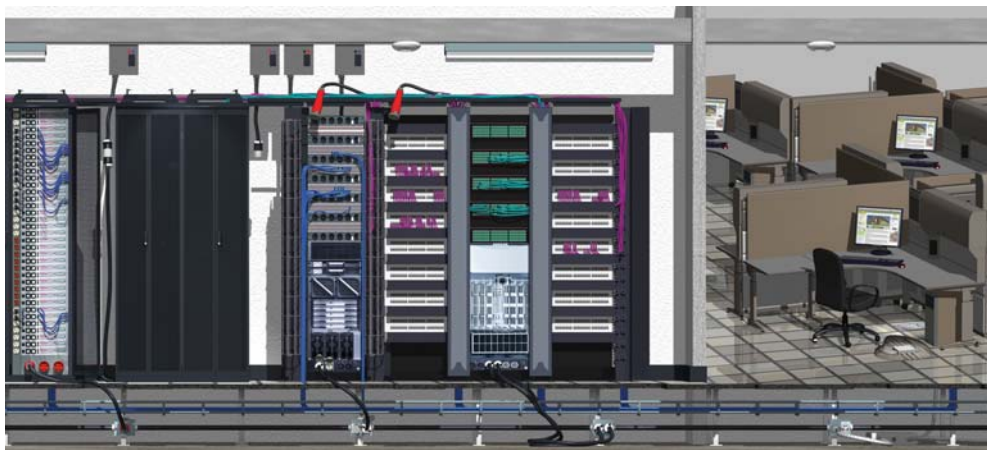

Cat 6A delivers high performance computing (HPC) to the desktop.

